

HSBC 225 S

Integral cylinder	2
-------------------	---

Table of contents

1	Special information	3	17	Guarantee	18
2	General information	3	18	Environment and recycling	18
2.1	Symbols in this document	3			
2.2	Units of measurement	3			
3	Safety.....	3			
3.1	Structure of the warning notices.....	3			
3.2	Intended use	4			
3.3	Foreseeable misuse.....	4			
3.4	Safety instructions	4			
4	Appliance description.....	4			
4.1	Appliance compatibility	4			
4.2	Standard delivery	5			
4.3	Required accessories.....	5			
4.4	Optional accessories.....	5			
5	Transportation (qualified contractors)	5			
6	Storage	5			
7	Installation (qualified contractors).....	5			
7.1	Installation site.....	5			
7.2	Minimum clearances	5			
7.3	Siting the appliance	6			
7.4	DHW connection	6			
7.5	Heating water connection.....	6			
7.6	Filling the system	7			
8	Commissioning (qualified contractors)	8			
8.1	Check to be carried out before commissioning the heat pump manager.....	8			
8.2	Commissioning the heat pump manager	8			
8.3	Appliance handover	8			
9	Settings.....	8			
10	Cleaning (operators)	9			
11	Maintenance (qualified contractors)	9			
11.1	Draining the appliance	9			
11.2	Flushing the system	9			
12	Troubleshooting (operators).....	10			
13	Troubleshooting (qualified contractors)	11			
14	Shutting down the system	11			
15	Specification	11			
15.1	Dimensions and connections	11			
15.2	Installation example	13			
15.3	Hydraulic diagram	13			
15.4	Data table	13			
16	Logbook for installation, commissioning and main- tenance.....	14			
16.1	Commissioning information	15			
16.2	Maintenance interval log.....	16			

1 Special information

- The appliance may be used by children over 8 years of age and persons with reduced physical, sensory or mental capabilities or a lack of experience and expertise, provided that they are supervised or they have been instructed on how to use the appliance safely and have understood the potential risks. Children must never play with the appliance. Cleaning and user maintenance must not be carried out by children without supervision.
- Observe all applicable national and regional regulations and instructions.
- Observe minimum clearances (see chapter *Minimum clearances* [▶ 5]).
- Only a qualified contractor should carry out installation, commissioning, maintenance and repair of the appliance.
- Always fill the appliance with water before switching it on.
- The appliance must be installed in compliance with the applicable building regulations.
- The terminal box is subject to continuous voltage. Prior to any electrical work, always disconnect the power supply and safeguard against reconnection during ongoing work.
- The connection to the power supply must be in the form of a permanent connection. Ensure the appliance can be separated from the power supply by an isolator that disconnects all poles with at least 3 mm contact separation.

DHW cylinder

- Drain the appliance as described in chapter *Draining the appliance* [▶ 9].
- Observe the maximum permissible pressure (see chapter *Data table* [▶ 13]).
- The appliance's DHW cylinder is pressurised. During the heat-up process, expansion water will drip from the safety valve.
- Regularly activate the safety valves to prevent them from seizing up, e.g. due to limescale deposits.
- The safety valve drain connections must remain open to atmosphere.
- The safety valve overflows must not be sealed or blocked off.

2 General information



Read these instructions carefully before using the appliance and retain them for future reference. Pass on these instructions along with the appliance as necessary.

2.1 Symbols in this document

Symbol	Meaning
	This symbol indicates possible property damage, equipment damage, consequential damage or environmental damage.
	General information is indicated by the adjacent symbol.
	This symbol indicates that you have to do something.
	This symbol indicates that you must fulfil certain prerequisites before you perform the following steps.
	This symbol indicates a result or intermediate result.
	These symbols show you the software menu level (in this example level 3).
[▶ 11]	This symbol indicates a reference to the corresponding page number (page 11 in this example).

2.2 Units of measurement

All measurements are given in mm unless stated otherwise.

3 Safety

3.1 Structure of the warning notices

3.1.1 Section-specific warning notices

Section-specific warning notices apply to all steps in the section.

Injury

CAUTION



Type and source of risk

Consequence(s) of failure to observe the warning notice

▶ Hazard prevention measure(s)

Property damage, consequential losses, environmental pollution

NOTICE



Type and source of risk

Consequence(s) of failure to observe the warning notice



▶ Hazard prevention measure(s)

3.1.2 Embedded warning notices

Embedded warning notices apply only to the step immediately following the notice.

- ▶ **SIGNAL WORD: Consequence(s) of failure to observe the warning notice. Hazard prevention measure(s).** Step to which the warning notice refers

3.1.3 Key to symbols

Symbol	Type of risk
	Injury
	Electrocution
	Burns, scalding

3.1.4 Signal words

Signal word	Meaning
DANGER	Failure to observe this information will result in death or serious injury.
WARNING	Failure to observe this information may result in death or serious injury.
CAUTION	Failure to observe this information may result in moderate or minor injury.
NOTICE	Failure to observe this information may result in property damage, consequential losses or environmental damage.

3.2 Intended use

The appliance is used for DHW heating and for heating rooms.

The appliance is intended for domestic use. It can be used safely by untrained persons. The appliance can also be used in non-domestic environments, e.g. in small businesses, as long as it is used in the same way.

Observation of these instructions and of instructions for any accessories used is also part of the intended use of this appliance.

3.3 Foreseeable misuse

Any other use beyond that described shall be deemed to be outside the intended use.

Using the appliance for heating fluids other than water or for water supplemented with chemicals, such as brine, is also deemed inappropriate.

Never use the appliance for cooling.

3.4 Safety instructions

Injury

- There is a risk of scalding at outlet temperatures in excess of 43 °C.
- The appliance may be used by children over 8 years of age and persons with reduced physical, sensory or mental capabilities or a lack of experience and expertise, provided that they are supervised or they have been instructed on how to use the appliance safely and have understood the potential risks. Children must never play with the appliance. Cleaning and user maintenance must not be carried out by children without supervision.
- The safety valve overflows must not be sealed or blocked off.
- It is not permitted to carry out modifications or conversions on the appliance.
- Unsuitable spare parts and accessories may jeopardise user and appliance safety. Always use original spare parts and original accessories.

- We recommend a DHW temperature of at least 55 °C to ensure optimum hygiene conditions. If operating the appliance at a lower DHW temperature, regularly heat the cylinder content to 60 °C.

Property damage, consequential losses, environmental pollution

- The DHW cylinder is under supply pressure. If no expansion vessel is installed, expansion water will drip from the safety valve during heat-up. If water continues to drip after heating has stopped, inform your qualified contractor.
- Consult building regulation G3.

4 Appliance description

The buffer cylinder and DHW cylinder with indirect coil are arranged one on top of the other. The indirect coil transfers the heat of the heating water from the heat pump to the DHW.

The appliance is connected hydraulically and electrically to the heat pump. In addition to the DHW cylinder and the buffer cylinder, further system components are integrated:

- Cylinder charging pump
- 3/2-way heating diverter valve
- Highly efficient circulation pump for a heating circuit without mixer
- Heat pump manager

DHW cylinder

The heating water heated by the heat pump is pumped through an indirect coil inside the DHW cylinder. The heat channelled through the indirect coil is thus transferred to the domestic hot water. The integral heat pump manager regulates the DHW heating to the required temperature.

Buffer cylinder

The steel cylinder provides hydraulic separation between the flow rates of heat pump and heating circuit. The heating water heated by the heat pump is transferred into the buffer cylinder by the cylinder charging pump. When a demand is issued, the integral circulation pump delivers the heating water to the heating circuit.

Heat pump manager (WPM)

The system is controlled by means of the integral heat pump manager.

The heat pump manager is suitable for the control of a direct heating circuit and a heating circuit with mixer.

You can set the times and temperatures for heating operation and DHW heating.

- ▶ Please observe the instructions for the heat pump manager.

Product registration

Register your product on the STIEBEL ELTRON website. Your complete data allows us to provide quick assistance if a guarantee claim is made. Our customer service department will take care of your system and ensure smooth handling.

4.1 Appliance compatibility

The appliance can be operated in conjunction with the following heat pumps:

- WPL 15-25 A (C) (S)
- WPL-A 05-07 HK 230 Premium

4.2 Standard delivery

- Instructions for the WPM heat pump manager
- 1x outside temperature sensor AF PT
- 1x T&P valve
- 2x sensor conduit \varnothing 6 mm / \varnothing 8 mm
- 3x adjustable feet
- 1x G3 kit
 - 1x multibloc
 - 1x drain pipe
 - 1x tundish
 - 1x DHW outlet
 - 1x circulation pump
 - 2x drain valves
 - 1x drain valve/safety valve for the buffer cylinder
 - 1x 3-way motorised valve
 - 1x DHW circulation pump
 - 1x expansion vessel (not fitted at the factory)

4.3 Required accessories

Safety assemblies and pressure reducers are available to suit the prevailing supply pressure. These type-tested safety assemblies protect the appliance against impermissible excess pressure.

4.4 Optional accessories

- 1x pressure reducer
- 1x remote control for heating operation
- 1x high limit safety cut-out STB-FB
- 1x water softening device HZEA

5 Transportation (qualified contractors)

NOTICE



Property damage

Lifting the appliance by the pipe connectors, valves, etc. may damage the appliance.

- ▶ Never lift the appliance by the pipe connectors, valves, etc.

▶ Transport the appliance at temperatures between $-20\text{ }^{\circ}\text{C}$ and $+60\text{ }^{\circ}\text{C}$.

▶ Transport the appliance in its original packaging.

6 Storage

▶ Store the appliance at temperatures between $-20\text{ }^{\circ}\text{C}$ and $+60\text{ }^{\circ}\text{C}$.

7 Installation (qualified contractors)

NOTICE



Property damage

The heating system to which the appliance is connected must be installed by a qualified contractor.

NOTICE



Incorrect water connection and installation work may cause property damage.

- ▶ Carry out all water connection and installation work in accordance with regulations.

7.1 Installation site

NOTICE



Property damage

Siting the appliance in a room with high humidity may damage the appliance.

- ▶ Never install the appliance in wet rooms.

The installation site must fulfil the following requirements:

- Free from the risk of frost
- Dry
- Adequate room height

The substrate on which the appliance is to be installed must meet the following conditions:

- Water resistant
- Horizontal
- Level
- Fixed
- Permanent
- Sufficient load bearing capacity (for weight of the appliance, see chapter *Data table* [▶ 13]).

7.2 Minimum clearances

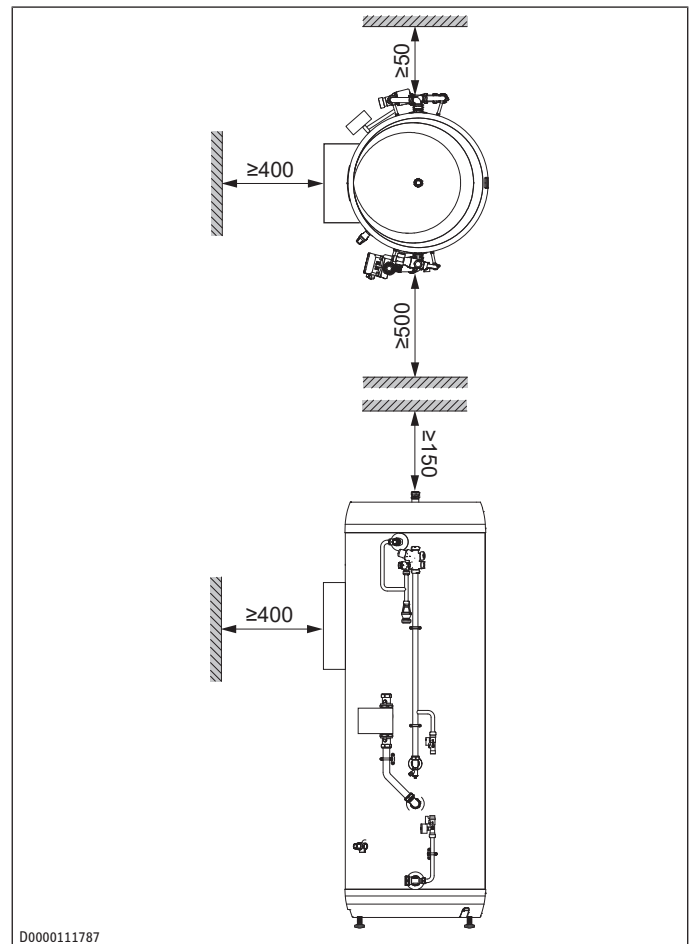

D0000111787

- ▶ Maintain the minimum clearances in order to ensure trouble-free operation of the appliance and to allow enough space for maintenance work.
- ▶ Ensure that there is sufficient space to lay the drain pipe from the appliance to a location outside the building in accordance with building regulation G3.

7.3 Siting the appliance

- ▶ Observe chapter *Minimum clearances* [▶ 5].

The appliance is equipped with three factory-fitted adjustable feet. Use the adjustable feet to compensate for any unevenness in the floor.

- ▶ Unscrew the adjustable feet at least 15 mm.
- ▶ Adjust the adjustable feet so that the appliance is stable and level.

7.4 DHW connection

NOTICE



Property damage

If the pressure in the DHW cylinder exceeds the maximum permissible pressure, the water may be discharged from the tap at excessively high pressure:

- ▶ Ensure that the maximum permissible pressure is not exceeded (see chapter *Data table* [▶ 13]).

NOTICE



Property damage

An open (non-pressurised) tap will not withstand the water pressure.

- ▶ Operate the appliance with pressure taps.



- ▶ Use suitable pipes.
- ▶ Use a suitable thread sealant.
- ▶ Seal off unused connection apertures.

- ✓ The cold water line is made from hot-dip galvanised steel, stainless steel, copper or plastic.
- ✓ The DHW line is made from stainless steel, copper or plastic.

- ▶ **NOTICE: Foreign bodies, such as welding pearls, rust or sealing material, can impair the operational reliability of the appliance.** Flush the pipework thoroughly before connecting the appliance.

7.4.1 Water connection



- ▶ Use suitable pipes.
- ▶ Use a suitable thread sealant.
- ▶ Seal off unused connection apertures.

- ▶ Connect the cold water line to the cold water inlet (see chapter *Installation example* [▶ 13]).
- ▶ Connect the DHW line to the DHW outlet (see chapter *Installation example* [▶ 13]).
- ▶ Install the expansion vessel.

7.4.2 Drain pipe



Drain pipes must be temperature-resistant in accordance with building regulation G3. The end of the outlet pipe must be in a safe and clearly visible location. For further information, contact your local authority planning department.

Permissible drain pipe materials:

- Metal

Drain from a low height (up to 100 mm above outside areas):

- To prevent contact and ensure visibility, a wire mesh or similar safeguard must be fitted in outside areas where children play or may come into contact with drain pipes.

Drain from a greater height:

- The drain pipe can be routed via a metal funnel and a metal downpipe.
- The drain can also be laid on a temperature-resistant roof. The end of the drain pipe must be at least 3 m away from any plastic guttering. The tundish must be clearly visible.

If multiple systems are connected by a split drain pipe:

- The split drain pipe must be at least one size larger than the biggest drain pipe being connected.

- ▶ Size the drain pipe so that water can drain off unimpeded when the T&P valve is fully opened (see chapter *Hydraulic diagram* [▶ 13]).

- ▶ Ensure that the drain pipe of the T&P valve is open to the atmosphere.

- ▶ Install the T&P valve drain pipe with a constant fall to the drain (see chapter *Hydraulic diagram* [▶ 13]).

- ▶ Secure the drain pipe to prevent any movement in the event of water being discharged.

7.5 Heating water connection

NOTICE



Property damage

The heating system to which the appliance is connected must be installed by a qualified contractor.

NOTICE



Incorrect water connection and installation work may cause property damage.

- ▶ Carry out all water connection and installation work in accordance with regulations.

NOTICE



Property damage

When fitting additional shut-off valves, install a further safety valve in an accessible location on the heat generator itself or in the flow line in close proximity to the heat generator. There must not be a shut-off valve between the heat generator and the safety valve.

Heating circuit oxygen diffusion

NOTICE



Property damage

In underfloor heating systems with plastic pipes that are permeable to oxygen and in open vented heating systems, oxygen diffusion may lead to corrosion on the steel components of the heating system (e.g. on the indirect coil of the DHW cylinder, on buffer cylinders, steel radiators or steel pipes).

- ▶ Avoid open vented heating systems and under-floor heating systems with plastic pipes that are permeable to oxygen.

NOTICE



Property damage

The products of corrosion (e.g. rusty sludge) can settle in the heating system components, which may result in a lower output or fault shutdowns due to reduced cross-sections.

Supply lines

The maximum permissible line length between the appliance and the heat pump will vary, depending on the version of the heating system (pressure drop). As a standard value, assume a maximum line length of 10 m and a pipe diameter of 22-28 mm.

- ▶ Protect the flow and return lines against frost with sufficient thermal insulation. The thermal insulation must be at least twice as thick as the diameter of the pipe. Provide thermal insulation in accordance with applicable regulations.
- ▶ Also protect all supply lines against humidity, damage and UV radiation by means of a conduit.

Pressure differential:

If the available external pressure difference is exceeded, the pressure drop in the heating system could result in a reduced heating output.

- ▶ When sizing the pipes, ensure that the available external pressure differential is not exceeded (see chapter *Data table* [▶ 13]).
- ▶ When calculating the pressure drops, take account of the flow and return lines and the pressure drop of the heat pump. The pressure drop must be covered by the available pressure differential.

7.5.1 Installing the heating water line



- ▶ Use suitable pipes.
- ▶ Use a suitable thread sealant.
- ▶ Seal off unused connection apertures.

- ▶ **NOTICE: Foreign bodies, such as welding pearls, rust or sealing material, can impair the operational reliability of the appliance.** Flush the pipework thoroughly before connecting the appliance.
- ▶ Install suitable pipes at the connections for the radiator and heat pump circuits (see chapter *Installation example* [▶ 13]).

7.6 Filling the system

NOTICE



- ▶ Never switch on the power before filling the system.
- ▶ First fill the appliance's DHW cylinder, then the buffer cylinder.

7.6.1 Filling the DHW cylinder

- ▶ Check that all connections are seated correctly and not leaking.
- ▶ Open a DHW valve of the draw-off point that is furthest away from the appliance.
- ▶ Leave the DHW valve open until the appliance is full and the pipes are free of air and dirt.
- ▶ Close the DHW valve.
- ▶ To remove residual air from the pipes, open all downstream DHW valves.
- ▶ Close all DHW valves.
- ▶ Carry out a tightness check.
- ▶ To open the T&P valve, turn it anti-clockwise.
- ▶ Check that water can flow unimpeded through the drain pipe to the drain.
- ▶ To close the T&P valve, continue turning the rotary selector anti-clockwise until the T&P valve closes.

7.6.2 Heating system

The heating system is filled with drinking water. To prevent damage to the heating system, comply with the following limits.

	Unit	Value
Water hardness	°dH	≤3
pH value		6.5-8.5
Chloride	mg/l	<30

You can find out the water hardness and the chlorine value in the fill water from the local water supplier.

- ▶ Observe local requirements (e.g. VDI 2035 in Germany).

We do not recommend desalinating the fill water, as this may cause a negative change in the pH value.

- ▶ If you desalinate the fill water or the pH value of the fill water is less than 8.2, check the pH value 8 to 12 weeks after installation, every time the system is topped up and the next time it is serviced.
- ▶ Do not add inhibitors or additives to the filling water.

Accessories for water softening

If you need to soften the fill water, you can use the following product.

- Water softening device HZEA
- HZEN replacement cartridge
- ▶ Recheck these limits 8-12 weeks after commissioning, every time the system is topped up and during the annual service.

Appliance in low-occupancy buildings

During regular operation, the connection lines and the system are protected by the frost protection function of the appliance.

Commissioning (qualified contractors)

If the appliance is disconnected from the power supply for a longer period of time (shutdown, prolonged power failure), drain the appliance on the water side. Otherwise the appliance is not protected against frost.

If it is not possible to detect power failures (for example if the system is in a holiday home left vacant for extended periods of time), the following protective measure can be taken.

- ▶ Add a suitable concentration of ethylene glycol to the fill water (20-40 % by vol.). Observe the instructions for the antifreeze. Only use antifreeze products which have been approved by us.
- ▶ Please note that antifreeze changes the density and viscosity of the fill water.

Product designation	
MEG 10	Heat transfer medium as concentrate based on ethylene glycol
MEG 30	Heat transfer medium as concentrate based on ethylene glycol

Filling the heating system

- ▶ Activate the following parameters in the heat pump manager.

Parameter
DIAGNOSIS / RELAY TEST SYSTEM / DRAIN HYD

- ✓ The appliance is disconnected from the power supply with omnipolar isolation.
- ▶ Check that all connections are seated correctly and not leaking.
- ▶ **NOTICE: Glycol residues in the hoses can lead to acidification of the heating water. This can result in corrosion and malfunction.** Use separate hoses for glycol and heating water.
- ▶ Fill the heating system via the drain valve and a filling hose (not supplied).
- ▶ Vent the pipework via the air vent valve on the heat pump.

8 Commissioning (qualified contractors)

Our customer support can assist with commissioning.

If this appliance is intended for commercial use, observe the rules of the relevant Health & Safety at Work Act during commissioning. For further details, check with your local authorising body (e.g. TÜV).

- ▶ Switch on the power supply to the appliance.

8.1 Check to be carried out before commissioning the heat pump manager

NOTICE



Property damage

If the heating water in underfloor heating systems is too hot, it can damage the floor covering.

- ▶ With underfloor heating systems, observe the maximum permissible temperature for the underfloor heating system.

- ▶ Check that the heating system is filled to the correct pressure and the quick-action air vent valve is closed.

- ▶ Check whether the outside sensor is correctly placed and connected.
- ▶ Check whether the power supply is connected correctly.
- ▶ Check whether the signal cable to the heat pump (bus cable) is correctly connected.

8.2 Commissioning the heat pump manager

- ▶ Commission the heat pump manager and make all settings in accordance with the heat pump manager commissioning instructions.



With the "PARALLEL MODE" setting, the charging pump is also activated in DHW mode.

- ▶ For DHW mode, ensure that the "PARALLEL MODE" option is set in the heat pump manager.

- ▶ Activate the following parameters in the heat pump manager.

Parameter	Setting
SETTINGS / DHW / STANDARD SETTING / DHW MODE	PARALLEL OPERATION



On appliances with a single-phase connection, set the heat pump manager as follows for calculating the amount of heat.

- ▶ Activate the following parameters in the heat pump manager.

Parameter	Setting
SETTINGS / HEATING / ELECTRIC BOOSTER HEATER / NUMBER OF STAGES	2

8.3 Appliance handover

- ▶ Explain the functions of the appliance to the user. Show the user how to operate the appliance.
- ▶ Make users aware of potential dangers.
- ▶ Hand over these instructions and, if applicable, the instructions for any accessories.
- ▶ Enter your contact details in the logbook for installation, commissioning and maintenance, which can be found at the end of these instructions.

9 Settings

NOTICE



Property damage

The system's active frost protection is not guaranteed if the power supply is interrupted.

- ▶ Never interrupt the power supply even outside the heating season.



The heat pump manager has an automatic summer/winter changeover so you can leave the system switched on in summer.

The system is controlled by means of the integral heat pump manager.

- ▶ Observe the relevant operating and installation instructions.

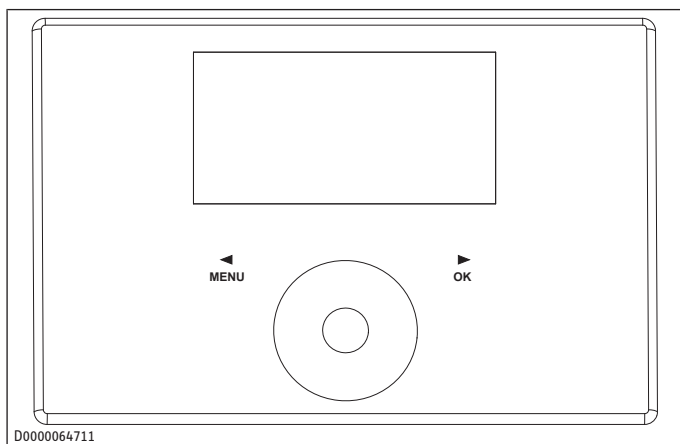

10 Cleaning (operators)

NOTICE



Property damage

Unsuitable cleaning agents can contaminate the DHW and damage the product.

- ▶ Never use cleaning agents that contain chlorine.

- ▶ Never use abrasive or corrosive cleaning agents. A damp cloth is sufficient for cleaning the appliance.

Almost every type of water will deposit limescale at high temperatures. Limescale will settle inside the appliance and affect its function and service life. The heating elements must therefore be descaled if necessary. A qualified contractor who is aware of the local water quality will tell you when the next descaling is due.

- ▶ Check the taps regularly. Limescale deposits at the tap outlets can be removed using commercially available descaling agents.
- ▶ Regularly activate the safety valve to prevent it from becoming stuck, e.g. due to limescale deposits.

11 Maintenance (qualified contractors)

WARNING



Electrocution

Incorrect electrical connection and installation work may lead to serious injury due to electrocution.

- ▶ Carry out all electrical connection and installation work in accordance with national and regional regulations.
- ▶ Ensure the appliance can be disconnected from the power supply by an isolator with at least 3 mm omnipolar contact separation.



- ▶ Drain the expansion vessel before checking the pre-charge pressure.
- ▶ Before removing the expansion vessel, depressurise the DHW cylinder and drain 10-20 l of water via the drain valve at the bottom of the DHW cylinder.

Component	Activity	Interval
Valves	Check all valves.	Annually

Component	Activity	Interval
Expansion vessel	Drain the expansion vessel. Check the pre-charge pressure of the expansion vessel. If the pre-charge pressure of the expansion vessel is not 3 bar, restore the value.	Annually
Dirt trap	Remove, clean and replace the dirt trap.	Annually
DHW cylinder	Close the shut-off valve in the cold water inlet. To depressurise the DHW cylinder, open a DHW valve on the next draw-off point.	Annually
Pipes and drain hoses	Check the pipes and drain connections.	Annually
Electrical connections	Check the electrical connections.	Annually
Taps	Check the taps.	Annually

11.1 Draining the appliance

WARNING



Burns

Hot water may escape when draining the appliance.

- ▶ Wear heat-resistant protective gloves.

WARNING



Burns

The water temperature in the cylinder can be up to 70 °C and may cause scalding.

- ▶ Open a DHW valve.
- ▶ Allow the water to run at the maximum pressure and temperature setting for at least 3 minutes before draining the appliance.
- ▶ Close the DHW valve.



Draining must be carried out in compliance with the applicable building regulations.

11.1.1 Draining the buffer cylinder

- ▶ Isolate the appliance from the power supply.
- ▶ Drain the buffer cylinder via the drain valve in the lowest installed pipe.

11.1.2 Draining the DHW cylinder

- ▶ Close the shut-off valve in the cold water inlet.
- ▶ Open a DHW valve on a draw-off point.
- ▶ Drain the DHW cylinder via the drain valve in the cold water line.

11.2 Flushing the system

- ▶ If the system requires flushing, allow at least 50 l of water to run from the DHW cylinder at the greatest possible flow rate.
- ▶ Close the DHW valves on the draw-off points.
- ▶ Drain the appliance (see chapter *Draining the appliance* [▶ 9]).

12 Troubleshooting (operators)

DHW cylinder

Fault	Possible cause	Remedy
The appliance does not supply hot water.	No voltage at the appliance.	Check that the appliance is connected to the power supply.
	A fuse in the distribution board has blown.	Check that the appliance is connected to the power supply. If required, disconnect the appliance from the power supply and replace the fuses/reset the MCBs. Reconnect the appliance to the power supply. If the fuse/MCB blows/trips again, notify a qualified contractor.
The appliance does not supply enough hot water.	The DHW line is leaking.	Notify a qualified contractor.
	Your household has high DHW consumption.	Increase the temperature setting to 70 °C. Observe the instructions for the heat pump manager. You require an appliance with a larger capacity.
The DHW temperature is not high enough.	The temperature setting is not high enough.	Increase the temperature setting to 70 °C. Observe the instructions for the heat pump manager.
	The mixer tap is faulty.	Notify a qualified contractor.
The safety switch or earth switch trips repeatedly.	There is an electrical fault.	Isolate the appliance from the power supply. Notify a qualified contractor.
Very hot water is continuously leaking from the tundish.	The high limit safety cut-out, temperature controller or T&P valve is not working correctly.	Isolate the appliance from the power supply. Also isolate all units indirectly connected to the system. Notify a qualified contractor.
Banging noises come from the pipes when the DHW valves are closed.	If a DHW valve is closed too quickly, the pressure in the pipes increases rapidly.	If the noises are annoying, arrange for an expansion vessel to be installed. Notify a qualified contractor.
The high limit safety cut-out trips.	Incorrect wiring.	Reduce the temperature setting. Please observe the instructions for the heat pump manager.
	The temperature controller is not working correctly.	If operating the appliance is still not possible, notify a qualified contractor.

Fault	Possible cause	Remedy
The high limit safety cut-out trips.	Incorrect wiring.	Perform the actions listed in the chapter link "Resetting the safety temperature controller". Reduce the temperature setting (see chapter "Temperature setting"). If operating the appliance is still not possible, notify a qualified contractor.
	The immersion heater or cylinder temperature controller is not working properly.	
	The temperature setting is too high.	

Buffer cylinder

Fault	Possible cause	Remedy
The heating system does not heat up.	A fuse in the distribution board has blown.	Check whether the fuses/MCBs in your distribution board have blown. If required, disconnect the appliance from the power supply and replace the fuses/reset the MCBs. Reconnect the appliance to the power supply. Contact your qualified contractor if the fuse/MCB blows/trips again after the appliance is connected to the power supply.
	The heating system contains air.	Vent the heating system as described in the instructions for the heat pump.
	The heating circuit pump is out of operation.	Notify a qualified contractor.
	The non-return valves are set incorrectly.	
The safety valve of the heating system is dripping.	The expansion vessel is faulty.	Notify a qualified contractor.
	The safety valve is faulty.	
	The pressure in the heating system is too high.	
The heating circuit must be refilled frequently.	The heating system is leaking.	Notify a qualified contractor.

► If you cannot remedy the fault, contact your qualified contractor.

The contact details for the qualified contractor can be found in the logbook for installation, commissioning and maintenance at the end of these instructions.

► To facilitate and speed up your enquiry, please provide the qualified contractor with the number from the type plate.

The type plate is located on the front of the appliance above the heat pump manager.

Example type plate

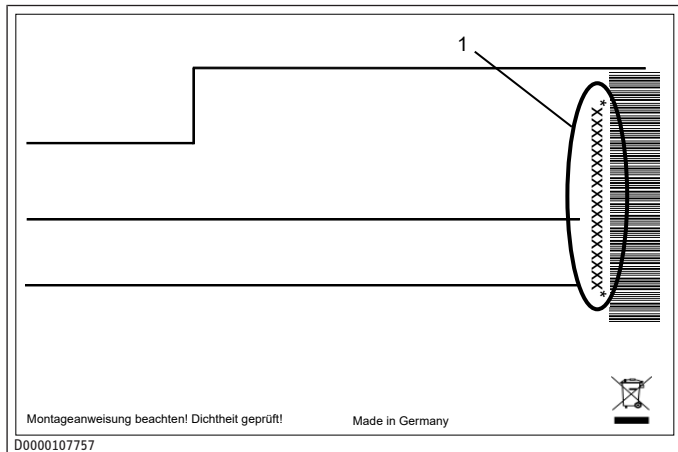

1 Number on the type plate

13 Troubleshooting (qualified contractors)



- ▶ Drain the expansion vessel before checking the pre-charge pressure.
- ▶ Before removing the expansion vessel, depressurise the DHW cylinder and drain 10-20 l of water via the drain valve at the bottom of the DHW cylinder.

Buffer cylinder

Fault	Possible cause	Remedy
The heating system does not heat up	No voltage at the appliance. The power cable is damaged.	Replace the power cable.
	The non-return valves are set incorrectly.	Check that the non-return valves ensure the correct restriction.
The safety valve of the heating system is dripping.	The expansion vessel is faulty.	Open the Schrader valve on the expansion vessel. If water is discharged, replace the expansion vessel.
	The safety valve is faulty.	Replace the safety valve.

DHW cylinder

Fault	Possible cause	Remedy
The safety valve is dripping.	The pressure is too high.	Install an expansion vessel to accommodate for any expansion during heating. Install a pressure reducer for stable pressure in the water lines. Adjust the pressure reducer according to the pressure in the expansion vessel.
	The safety valve is worn. There is dirt between the diaphragm and the safety valve seat.	Flush the safety valve with water. Open the safety valve for one minute. Close the safety valve. If the safety valve continues to drip, replace it.
Water is leaking intermittently from the tundish.	The high limit safety cut-out, thermostat or T&P valve is not working correctly.	Isolate the appliance from the power supply. Close the cold water inlet. Open a DHW valve on a draw-off point. Open the T&P valve. Leave the T&P valve in this position for 30 seconds. Close the T&P valve. Check the pre-charge pressure of the expansion vessel. If required, adjust the pre-charge pressure (see chapter <i>Maintenance (qualified contractors)</i> [▶ 9]). Open the cold water inlet. If water is flowing through the open DHW valve, close the DHW valve. Switch on the power supply again.

14 Shutting down the system

- ▶ If you take the system out of operation, set the heat pump manager to standby so that the safety functions that protect the appliance (e.g. frost protection) remain active.

15 Specification

15.1 Dimensions and connections

Specification

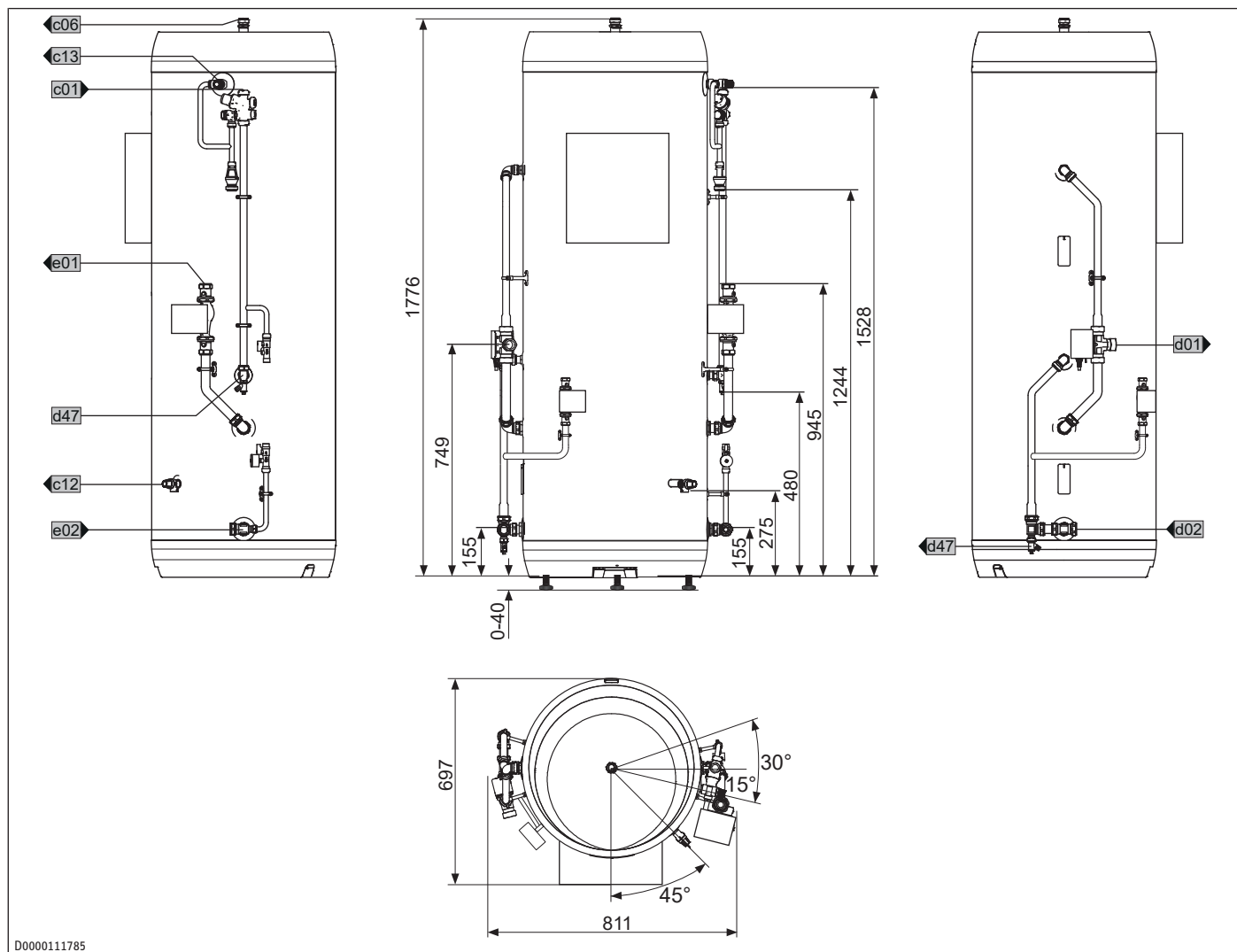

D0000111785

				HSBC 225 S
c01	Cold water inlet	Diameter	mm	22
c06	DHW outlet	Diameter	mm	22
c12	Safety valve drain	Diameter	mm	G 1/2
c13	T&P valve			G 1/2
d01	Heat pump flow	Diameter	mm	22
d02	Heat pump return	Diameter	mm	22
d47	Drain	Diameter	mm	14
e01	Heating flow	Diameter	mm	22
e02	Heating return	Diameter	mm	22

15.2 Installation example

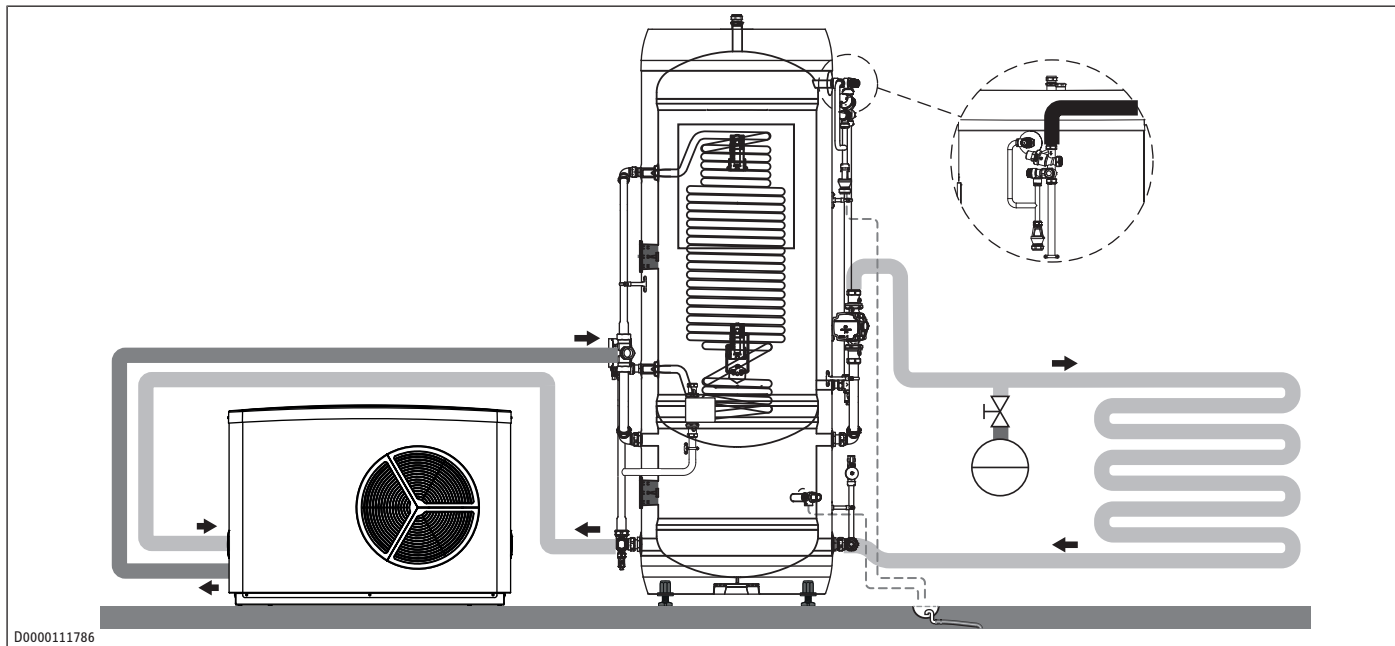

D0000111786

15.3 Hydraulic diagram

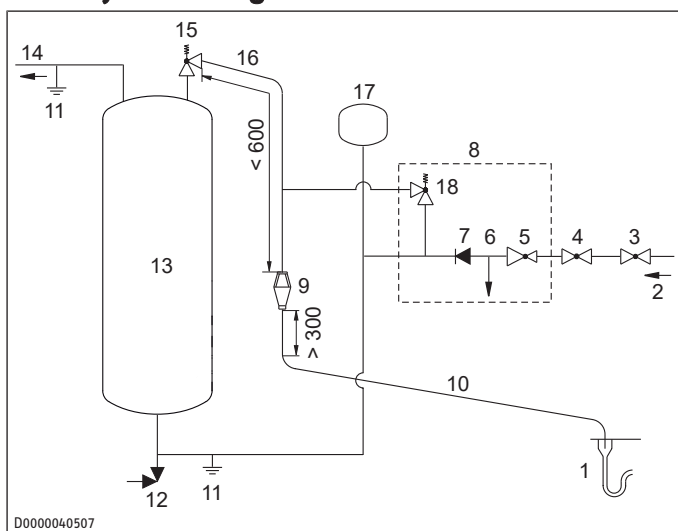

D0000040507

1 Drain with trap 2 Cold water inlet

- | | |
|-------------------------------------|--|
| 3 Shut-off valve | 4 Dirt trap |
| 5 Pressure reducer | 6 Balanced cold water outlet |
| 7 Test valve | 8 Safety assembly |
| 9 Tundish | 10 Drain pipe (D2) from tundish with a constant fall |
| 11 Equipotential bonding connection | 12 Drain valve |
| 13 Cylinder | 14 DHW outlet |
| 15 T&P valve | 16 Drain pipe (D1) from T&P valve to tundish |
| 17 Expansion vessel | 18 Expansion valve |

	G 1/2		
Diameter of drain pipe (D1)	min. mm	15	
Diameter of drain pipe (D2)	min. mm	22	28 35
Maximum permissible pressure drop, expressed as length of straight pipe (i.e. no elbows or bends)	m	9	18 27
Pressure drop per elbow or bend	m	0.8	1.0 1.4

15.4 Data table

		HSBC 225 Trend	
		206045	
Hydraulic data			
Large DHW cylinder	l	225	
Nominal capacity, buffer cylinder	l	65	
Surface area, heat exchanger	m ²	3.1	
Capacity, heat exchanger	l	17	
External available pressure differential, circulation pump, heat pump at 1.0 m ³ /h	hPa	576	
External available pressure differential, circulation pump, heat pump at 1.5 m ³ /h	hPa	176	
External available pressure differential, circulation pump, heating circuit 1 at 1.0 m ³ /h	hPa	725	
External available pressure differential, circulation pump, heating circuit 1 at 1.5 m ³ /h	hPa	663	
External available pressure differential, circulation pump, heating circuit 1 at 2.0 m ³ /h	hPa	444	
DHW volume > 40 °C	l	360	
Pressure drop at 1.0 m ³ /h, indirect coil, top	hPa	130	
Max. operating temperature heating water	°C	70	
Application limits			
Max. permissible pressure (design pressure), DHW	MPa	0.3	
Max. permissible pressure (design pressure), heat exchanger, top	MPa	0.2	
Test pressure, DHW cylinder	MPa	1.0	

Specification

		HSBC 225 Trend
Max. flow rate	l/min	25
Max. permissible pressure (design pressure), buffer cylinder	MPa	0.2
Test pressure, buffer cylinder	MPa	0.2
Max. permissible temperature	°C	70
Power consumption		
Max. power consumption, charging pump	W	60
Max. power consumption, circulation pump, heating side	W	60
Energy data		
Standby energy consumption/ 24 h at 65 °C	kWh	1.82
Energy efficiency class		A
Electrical data		
Rated voltage, control unit	V	230
Phases, control unit		1/N/PE
Control unit fuse protection	A	1 x B 16
Frequency	Hz	50
Output data		
Tested to standard		EN 12897:2016
Values		
Nominal design flow rate of heating system at A-7/W35 and 7 K	m ³ /h	1.4
Safety assembly, max. supply pressure	MPa	1
Recommended operating pressure, heating circuit	MPa	0.2
Recommended operating pressure, DHW	MPa	0.3
Pressure reducer, set pressure	MPa	0.3
T&P valve, nominal set temperature	°C	90
T&P valve, nominal set pressure	MPa	0.45
T&P valve, nominal diameter		DN 15
Expansion valve nominal pressure	MPa	4.5
Expansion vessel, DHW - pre-charge pressure	MPa	0.3
Expansion vessel, DHW - volume	l	18
Dimensions		
Height	mm	1776
Width	mm	765
Depth	mm	685
Height when tilted	mm	1870
Weights		
Weight, full	kg	369.5
Weight, empty	kg	79.5

16 Logbook for installation, commissioning and maintenance

Datasheet for installation, commissioning and maintenance of mains pressure DHW cylinders

CUSTOMER INFORMATION

NAME

ADDRESS

TEL: NO:

INSTALLER DETAILS

DATE

COMPANY NAME

ADDRESS

NAME OF INSTALLER

TEL: NO:

DETAILS OF REGISTRATION

NO: OF REGISTERED COMPANY ID CARD (IF APPLICABLE)

COMMISSIONING CONTRACTOR (IF DIFFERENT)

DATE

COMPANY NAME

ADDRESS

NAME OF COMMISSIONING CONTRACTOR

TEL: NO:

DETAILS OF REGISTRATION

NO: OF REGISTERED COMPANY ID CARD (IF APPLICABLE)

APPLIANCE AND TIME CONTROL INFORMATION

MANUFACTURER: STIEBEL ELTRON

MODEL

CAPACITY |

PRODUCT NO:

TYPE SEALED UNVENTED

TIME CONTROL PROGRAMMER

TIME SWITCH

IMPORTANT

- Keep this logbook in a safe place for future use.
- This logbook must be completed in full by the competent person(s) who commissioned the system and then handed over to the customer. Once these steps have been carried out, the logbook is a commissioning certificate which serves as proof of compliance with the relevant building regulations.
- If the appliance has not been installed and commissioned in accordance with the manufacturer's instructions, the guarantee may become void.
- The installer is responsible for completing this logbook and handing it over to the customer. Failure to observe this may void the guarantee for the DHW cylinder.

This will not affect your statutory rights.

16.1 Commissioning information

BOILER PRIMARY SETTINGS (INDIRECT HEATING ONLY) ALL BOILERS		
IS THE PRIMARY SYSTEM SEALED UNVENTED OR OPEN VENTED?	SEALED UNVENTED	<input type="checkbox"/>
	OPEN VENTED	<input type="checkbox"/>
WHAT IS THE BOILER FLOW TEMPERATURE?	°C	
ALL SYSTEMS WITH MAIN PRESSURE		
WHAT IS THE INCOMING STATIC COLD WATER PRESSURE AT THE PRESSURE REDUCING VALVE INLET?	bar	
WAS THE STRAINER (IF FITTED) CLEANED OF INSTALLATION RESIDUES?	YES	<input type="checkbox"/>
	NO	<input type="checkbox"/>
HAS A WATER SOFTENER BEEN INSTALLED?	YES	<input type="checkbox"/>
	NO	<input type="checkbox"/>
WHICH TYPE OF WATER SOFTENER HAS BEEN INSTALLED?		
SEALED UNVENTED SYSTEMS		
HAVE A COMBINED TEMPERATURE AND PRESSURE LIMITING VALVE AND EXPANSION VALVE BEEN FITTED AND DISCHARGE TESTED?	YES	<input type="checkbox"/>
	NO	<input type="checkbox"/>
IS THERE A SHUTDOWN DEVICE FOR THE PRIMARY ENERGY SOURCE (NORMALLY A 2-WAY VALVE)?	YES	<input type="checkbox"/>
	NO	<input type="checkbox"/>
HOW IS THE PRESSURE REDUCING VALVE SET (IF FITTED)?	bar	
WHERE IS THE PRESSURE REDUCING VALVE LOCATED?		
HAS THE EXPANSION VESSEL OR THE INTERNAL AIR SPACE BEEN CHECKED?	YES	<input type="checkbox"/>
	NO	<input type="checkbox"/>
WHAT IS THE DHW TEMPERATURE AT THE NEAREST OUTLET?	°C	
ALL PRODUCTS		
DOES THE DHW SYSTEM COMPLY WITH THE RELEVANT BUILDING REGULATIONS?	YES	<input type="checkbox"/>
HAS THE SYSTEM BEEN INSTALLED AND COMMISSIONED ACCORDING TO THE MANUFACTURER'S INSTRUCTIONS?	YES	<input type="checkbox"/>
HAVE YOU SHOWN THE CUSTOMER HOW TO OPERATE THE CONTROLS?	YES	<input type="checkbox"/>
HAVE YOU HANDED OVER ALL MANUFACTURER'S DOCUMENTS TO THE CUSTOMER?	YES	<input type="checkbox"/>
CONTRACTOR SIGNATURE		
CUSTOMER SIGNATURE		
(To confirm demonstration of the appliances and receipt of the instruction manual)		

16.2 Maintenance interval log

It is recommended that your DHW system is serviced regularly and that your maintenance personnel complete the corresponding maintenance interval log below.

MAINTENANCE PERSONNEL

Before completing the maintenance interval log below, please ensure that you have performed the maintenance as described in the manufacturer's operating and installation instructions and in compliance with all relevant regulations.

MAINTENANCE 1		MAINTENANCE 2	
DATE		DATE	
NAME OF MAINTENANCE PERSONNEL		NAME OF MAINTENANCE PERSONNEL	
COMPANY NAME		COMPANY NAME	
TEL. NO.		TEL. NO.	
REMARKS		REMARKS	
SIGNATURE		SIGNATURE	
MAINTENANCE 3		MAINTENANCE 4	
DATE		DATE	
NAME OF MAINTENANCE PERSONNEL		NAME OF MAINTENANCE PERSONNEL	
COMPANY NAME		COMPANY NAME	
TEL. NO.		TEL. NO.	
REMARKS		REMARKS	
SIGNATURE		SIGNATURE	
MAINTENANCE 5		MAINTENANCE 6	
DATE		DATE	
NAME OF MAINTENANCE PERSONNEL		NAME OF MAINTENANCE PERSONNEL	
COMPANY NAME		COMPANY NAME	
TEL. NO.		TEL. NO.	
REMARKS		REMARKS	
SIGNATURE		SIGNATURE	
MAINTENANCE 7		MAINTENANCE 8	
DATE		DATE	
NAME OF MAINTENANCE PERSONNEL		NAME OF MAINTENANCE PERSONNEL	
COMPANY NAME		COMPANY NAME	
TEL. NO.		TEL. NO.	
REMARKS		REMARKS	
SIGNATURE		SIGNATURE	

17 Guarantee

The guarantee conditions of our German companies do not apply to appliances acquired outside of Germany. In countries where our subsidiaries sell our products a guarantee can only be issued by those subsidiaries. Such guarantee is only granted if the subsidiary has issued its own terms of guarantee. No other guarantee will be granted.

We shall not provide any guarantee for appliances acquired in countries where we have no subsidiary to sell our products. This will not affect warranties issued by any importers.

18 Environment and recycling

- ▶ Dispose of the appliances and materials after use in accordance with national regulations.



- ▶ If a crossed-out waste bin is pictured on the appliance, take the appliance to your local waste and recycling centre or nearest retail take-back point for reuse and recycling.



This document is made of recyclable paper.

- ▶ Dispose of the document at the end of the appliance's life cycle in accordance with national regulations.

Comfort through Technology



4 017213 592358

STIEBEL ELTRON UK Ltd

Unit 12 Stadium Court / CH62 3RP Bromborough

Tel. 0151 346-2300

technical@stiebel-eltron.co.uk / www.stiebel-eltron.co.uk

A 359235-45547-9854
B 359234-45547-9854